

Campaign Bulletin 100002

Date: May 7, 2010
Subject: Floor Loading Information
Models and Serial Numbers Affected:
Z-80: Z80-101 to Z8009-2448
Allowable Hours: 30 minutes

Issue:

Genie Industries has determined that the above referenced machines were produced with the wrong floor loading information in the operator's manual and on the decals. This information indicates that the maximum wheel load is less than the actual maximum wheel load. **Incorrect floor loading information may result in the user operating the machine on a surface that is not capable of supporting the maximum wheel load.**

Action Required:

This bulletin requires replacement of the operating instructions manual and wheel load decals on the above referenced machine.

1. Locate all machines within the serial number ranges shown above.
Note: Enclosed is a list of affected machines under your account.
2. Locate and destroy any hard copies or electronic files in your inventory for the operator's manuals listed below:
 - P/N 82258 (1st edition_4th printing and previous versions)
 - P/N 82578 (2nd edition _4th printing and previous versions)
 - P/N 1000237 (3rd edition_3rd printing and previous versions)

Note: You can download the latest version of the Operating Instructions Manual from the Genie website located @ http://www.genieindustries.com/operator_manuals.asp

3. Using the table in the attached Parts Order Form, determine the Decal/Operator's Manual kit for your machine.
4. Completely fill out the kit Parts Order Form and return to Genie's Parts Department to receive the Decal/Operator's Manual Kit for your machine at no cost.

**FAILURE TO COMPLETE THIS BULLETIN MAY
RESULT IN DEATH OR SERIOUS INJURY.**

Campaign Bulletin 100002

5. Upon receipt of the kit, locate and destroy the wheel load decal P/N 82591 on your machine and replace with the decal from the kit.

Replacement of the operator's manual and decals must take place as soon as possible, but no later than 30 days from receipt of parts.

6. Locate and destroy wheel load decal P/N 82591 in your inventory.
7. Fill out and sign the Completion Form attached with the installation instructions and fax to Genie's warranty department to verify that this campaign bulletin has been completed.
8. Contact Genie's Service Parts department to receive credit for destroyed decal P/N 82591 from your inventory.

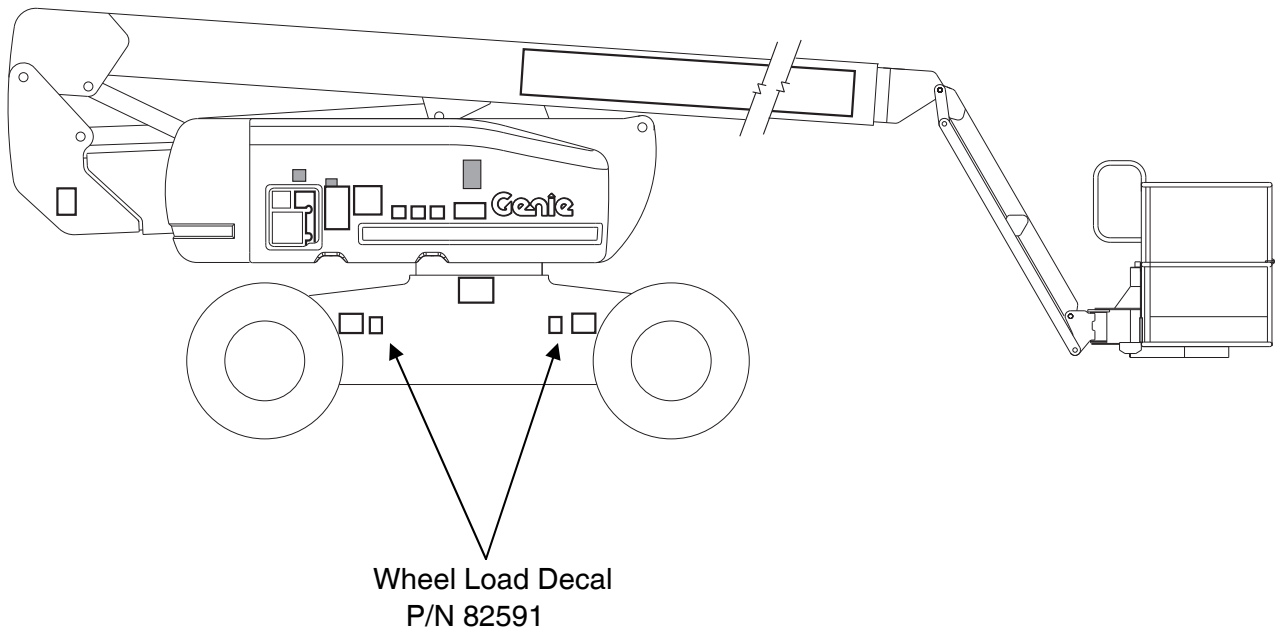

**FAILURE TO COMPLETE THIS BULLETIN MAY
RESULT IN DEATH OR SERIOUS INJURY.**



Campaign Bulletin 100002

Warranty:

The labor and travel miles required to perform this inspection and installation are covered under the provisions of our warranty agreement. Labor for each affected machine will be paid at a rate of \$60.00 U.S. per hour and travel at a rate of \$.50 U.S. per mile, converted into the currency of the appropriate country at the time of payment.

If you are the owner of an affected machine and are not an authorized Genie dealer, please contact your nearest Genie dealer for assistance with this campaign bulletin. Only Genie Authorized Dealers will be reimbursed for labor or any other costs associated with this bulletin under the provisions of our standard warranty terms and conditions.

Genie and ANSI requires that the seller of a Genie machine report to Genie the model and serial number of each machine sold, as well as the name, address, and telephone number of the new owner, within 60 days of the sale. OSHA and ANSI also require that the manufacturer’s campaign bulletins be completed. It is your responsibility to communicate this important information to all machine owners and applicable branches. If you require additional copies of this bulletin or have any questions, please contact Genie’s service department at:

- Unites States 800-536-1800
- Canada 425-881-1800
- Europe +31 653 221 908
- Australia 61 733751660
- All other locations 001-425-881-1800

Enclosures:

- Machine List Report
- New Owner Update Form
- Parts Order Form
- Completion Form

**FAILURE TO COMPLETE THIS BULLETIN MAY
RESULT IN DEATH OR SERIOUS INJURY.**



Campaign Bulletin 100002

New Owner Update Form
(for updating machine owner information only)

Genie and ANSI requires that the seller of a Genie machine report to Genie the model and serial number of each machine sold, as well as the name, address, and telephone number of the new owner, within 60 days of the sale.

- If you have sold a machine, list the complete model and serial number (example: Z80-101 or Z8006-800) and the name, address and phone number of the new owner

New Owner Information:

	Machine 1	Machine 2	Machine 3
Model*	_____	_____	_____
Serial Number*	_____	_____	_____
Owner Name*	_____	_____	_____
Address 1*	_____	_____	_____
Address 2	_____	_____	_____
City/State/Zip*	_____	_____	_____
Phone Number*	_____	_____	_____
Contact Person	_____	_____	_____

* *Required fields.*

Seller Information:

Date: _____

Company Name: _____

Account #: _____

Address: _____

(street) _____

(city) _____

State, zip code _____

Phone #: _____

- List any machines that could not be inspected or repaired because of the following:

Model & Serial Number	Scrapped	Exported	Stolen	Others (explain)
_____	-	-	-	-
_____	-	-	-	-
_____	-	-	-	-
_____	-	-	-	-

Fax to: United States 877-738-7530
 Canada 425-498-7530
 All other locations 001-425-498-7530



Campaign Bulletin 100002

Parts Order Form

Fax this form to Genie Industries to receive the indicated *Operator's Manual / Decal Kit* for your machine. List the model and serial number of each affected machine.

Serial Range	Kit Part Numbers					
	English	French	Spanish	Chinese	Korean	Portuguese-Brazilian
before Z-80-207	147517	147517FR	147517SP	147517CS	147517KO	147517PB
from 207 to 800	147518	147518FR	147518SP	147518CS	147519KO	147518PB
from 801 to 2448	147519	147519FR	147519SP	N/A	N/A	147519PB

- **Please list the complete model and serial number** (example: Z80-101 or Z8006-800).

Model & Serial Number	-	Kit P/N	Model & Serial Number	-	Kit P/N
_____	-	_____	_____	-	_____
_____	-	_____	_____	-	_____
_____	-	_____	_____	-	_____
_____	-	_____	_____	-	_____
_____	-	_____	_____	-	_____
_____	-	_____	_____	-	_____
_____	-	_____	_____	-	_____
_____	-	_____	_____	-	_____

Date: _____
 Company Name: _____
 Ordered by: _____
 Account # (If applicable): _____
 Address: _____
 (street): _____
 (city): _____
 (state, zip code): _____
 Phone: _____

Send Parts to: (If you would like to send parts to a different location)

Company Name: _____
 Attn: _____
 Account # (if applicable): _____
 Address: _____
 (street): _____
 (city): _____
 (state, zip code): _____
 Phone: _____

Fax to:	United States	888-274-6192
	Canada	425-556-8659
	All other locations	001-425-556-8659